

# Etrier pour boucle isolante, avec boulon rivé, acier inox

Référence E0928-02

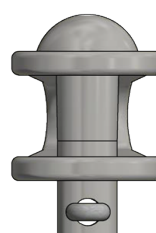
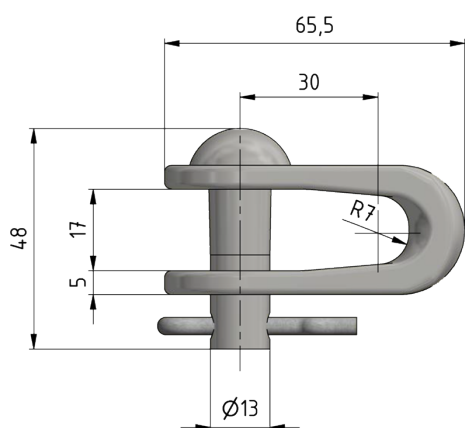

**Dimension**

Ø: 13 mm

B: 32 mm

C: 17 mm

E: 5 mm

F: 7 mm

A: 30 mm

**Matériel et poids**

Poids: 0.170 kg

Matériel: Acier inox

**Charges**

Charge de rupture: 50 kN