

D2469-01

HINGE WITH CLEVIS FORK VERTICAL, COMPLETE, TO BRACKETS

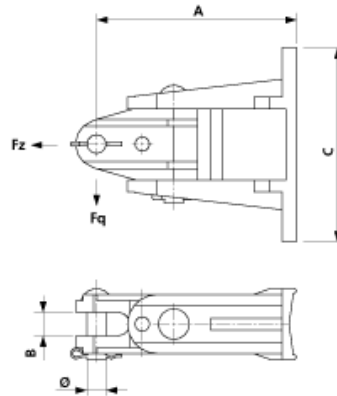
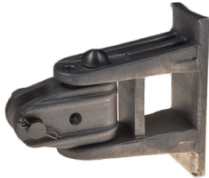

DIMENSIONS

A: 168 mm

C: 164.5 mm

B: 20 mm

Ø: 16 mm

MATERIAL AND WEIGHT

Material: Al/SST

Weight: 1.410 kg

LOADS

Breaking load F across: 14 kN

Breaking moment: with installation locking device 950 Nm

Breaking load F on traction: 38 kN

COMMENTS

- Attachment to round poles $D = > 150$ mm
- Pole clamps with band to be ordered separately
- The attachment material to bracket (straight or inclined) must be ordered separately