



CANTILEVER SYSTEM FOR RAILWAY, TRAMWAY AND TROLLEYBUS

–30%
STORAGE

–25%
WEIGHT

ARCAS (ADAPTABLE RAILWAY CANTILEVER SYSTEM)

A **patented** development by Kumm-ler+Matter designed on the basis of the tried-and-tested **modular system**. This system **reduces the number of parts in your inventory** to the mini-

mum. Because there are only a few standard parts, the system **can be installed on site much faster**. The overall weight is significantly reduced thanks to a skilful combination of

design and choice of materials. This system has been operated successfully in many different projects **across the globe since 1999**.

MODULAR ARCAS CANTILEVER

APPLICATION AREA



RAILWAY / LIGHT RAIL

- ✓ Voltage up to 25 kV/AC / 3 kV/DC
- ✓ For profile pole widths of 100–300 mm
- ✓ For round poles Ø115–500 mm
- ✓ Single and double insulation
- ✓ Silicone insulators
- ✓ Tubes Ø38–90 mm

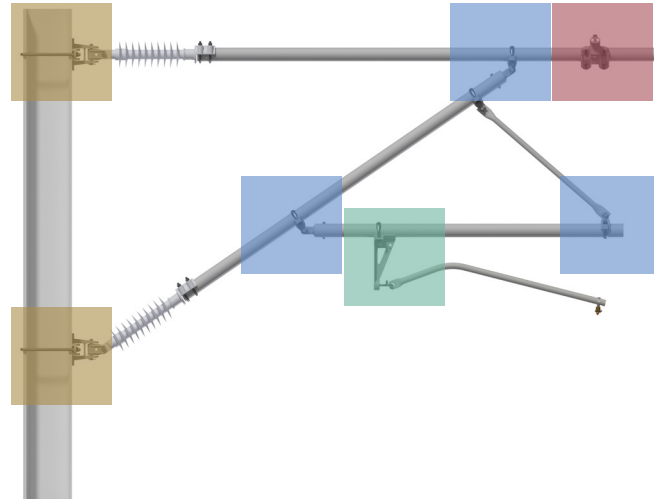

TRAMWAY

- ✓ Voltage up to 750 V/DC
- ✓ For profile pole widths of 100–300 mm
- ✓ For round poles Ø115–500 mm
- ✓ Double insulation
- ✓ Silicone insulators
- ✓ Tubes Ø60–90 mm

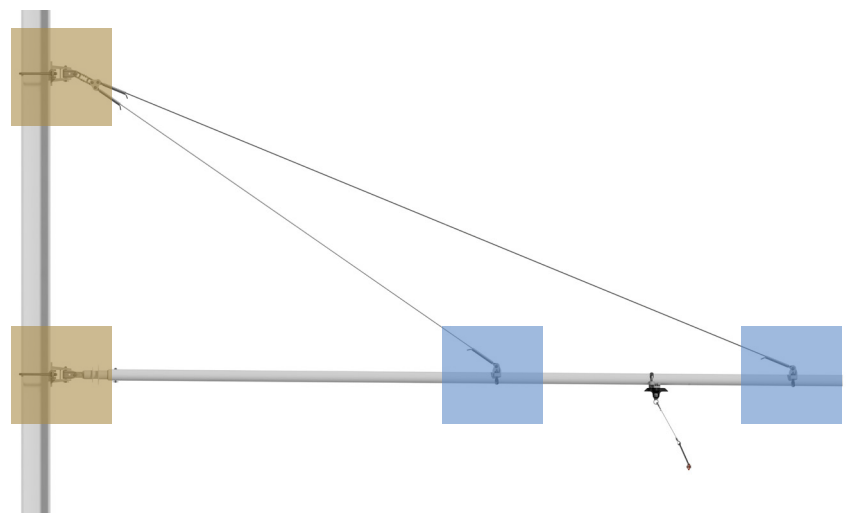

TROLLEYBUS

- ✓ Voltage up to 750 V/DC
- ✓ For profile pole widths of 100–300 mm
- ✓ For round poles Ø115–500 mm
- ✓ Double insulation
- ✓ Silicone insulators
- ✓ Tubes Ø60–90 mm

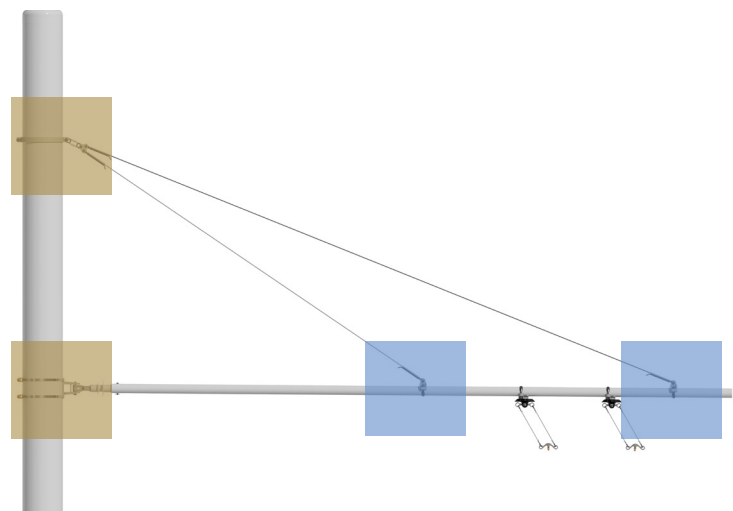

ONE SYSTEM – MULTIPLE POSSIBILITIES

MAST BRACKET

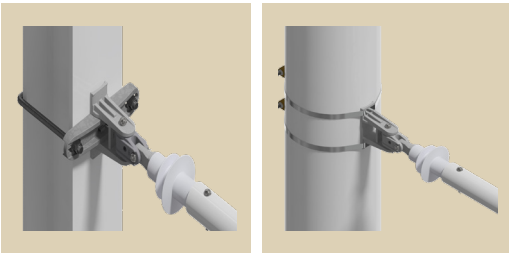
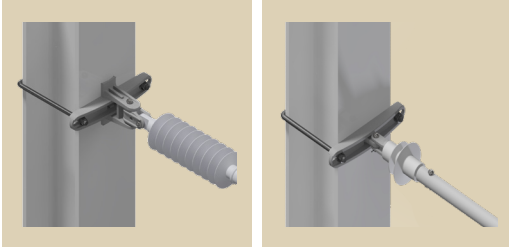

PIPE ATTACHMENT

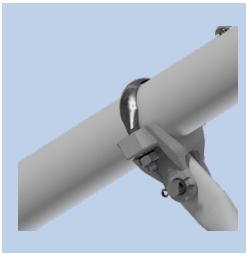
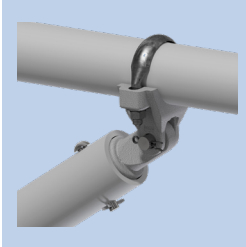

DROP BRACKET

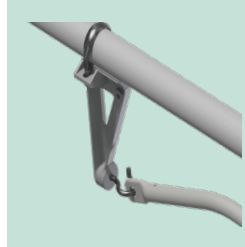

MESSENGER CABLE SUSPENSION

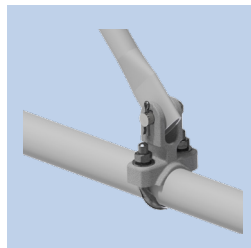
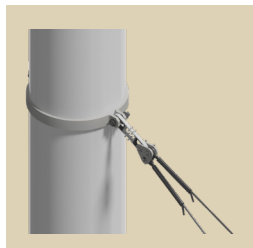
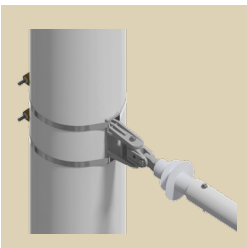
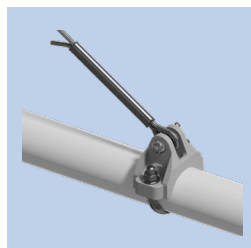
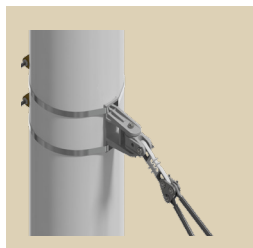
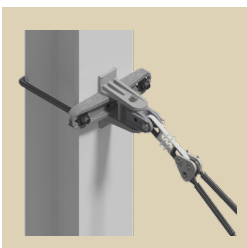
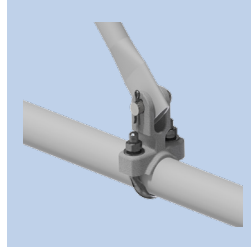
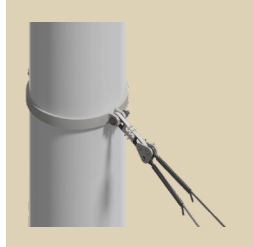
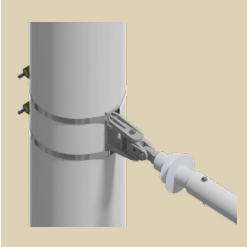
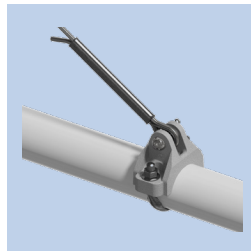
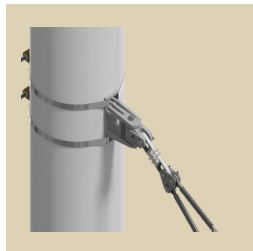
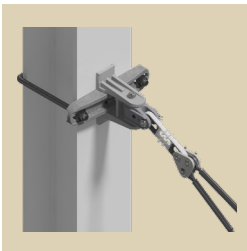
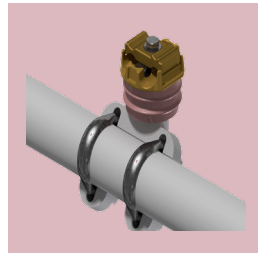
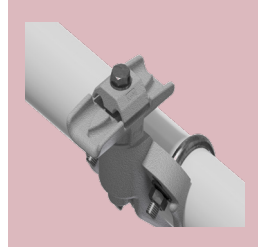

MINIMAL INVENTORY

Our tried-and-tested modular system comprising multifunctional parts reduces the number of required parts to the minimum.

SPEEDY INSTALLATION ON SITE

With just a few bolted or plug-type connections, fast pre-assembly and installation directly on site are guaranteed.

PROVEN QUALITY

All the products are made of corrosion-resistant materials. Tried-and-tested aluminium and bronze casting alloys provide the basis. Complemented by stainless steel connectors, they guarantee long service lifetimes with constant quality. The compact design reduces the systems weight by 25 percent as compared to other products.

YOUR ADVANTAGES AT A GLANCE

- ✓ **-30 % storage**
- ✓ **-25 % weight**
- ✓ **-20 % installation time**

- ✓ Excellent flexibility thanks to the modular system
- ✓ Cost-efficient – because ARCAS can be integrated into existing systems
- ✓ Doubly insulated systems in the DC section
- ✓ Re-usable joining pieces
- ✓ For tramways, local and long-distance traffic, regardless of the catenary

SPECIFICATIONS

- ✓ Tube materials of aluminium, steel or fibreglass reinforced plastic (FRP)
- ✓ Contact wire cross-section up to 180 mm² (350 MCM, USA) for 25 kN tensile load
- ✓ Messenger cable cross-section up to 255 mm² (500 MCM, USA) for 45 kN tensile load

TESTS AND STANDARDS

- ✓ EN 50119

Kummler+Matter Ltd
Rietstrasse 14
CH-8108 Dällikon

T +41 44 247 47 47
F +41 44 247 47 77
info.zuerich@kuma.ch

kuma.ch



FOR YOUR OVERHEAD CONTACT LINES