

A photograph of a railway section insulator assembly. It features a grey ceramic insulator with multiple disc-like segments, mounted on a metal frame. The assembly is suspended from a yellow overhead wire. Below it, a pantograph system is visible, consisting of several orange contact wires and metal runners. The background is a clear blue sky.

RAILWAY SECTION INSULATOR

-30%

INSTALLATION COST

HIGHLY INCREASED
SERVICE LIFETIME

KUSEC 25/15 kV AC, 3 kV DC

This innovative section insulator has been newly **developed by Kummler+Matter**. The runners consist of copper contact wire. The contact wire of the 25/15 kV models is additionally consisting of a very abrasion-resistant copper-magnesium alloy. Thanks to **this new design**, the section insulator

stays flat throughout the full length. This allows the pantograph to travel smoothly across the entire length of the component. **Maintenance intervals can be extended significantly** by using elevated, non-traversed insulators. The anchor clamp – an additional development by

Kummler+Matter – **makes it very simple to install the complete section insulator** and adjust its height. With its short overall length, the section insulator can be installed at almost any desired location in the contact line.

The logo for Kummler+Matter, featuring the company name in a bold, sans-serif font. The text is white and is set against a dark orange background that consists of two overlapping horizontal bars.

Kummler+Matter

RAILWAY SECTION INSULATOR 25 kV AC

Article no. B1552-01 - Complete with anchor clamps

Article no. B1597-01 - Centre piece with bolt

FAST INSTALLATION ON SITE

In case of a product change, the entire section insulator can be exchanged in next to no time thanks to the patented anchor clamps with their unique installation system.

SIMPLE HEIGHT ADJUSTMENT

The KUSEC 25 kV can be very easily adjusted to the desired height with two perforated suspension plates. The inclination is adjusted with the help of turnbuckles.

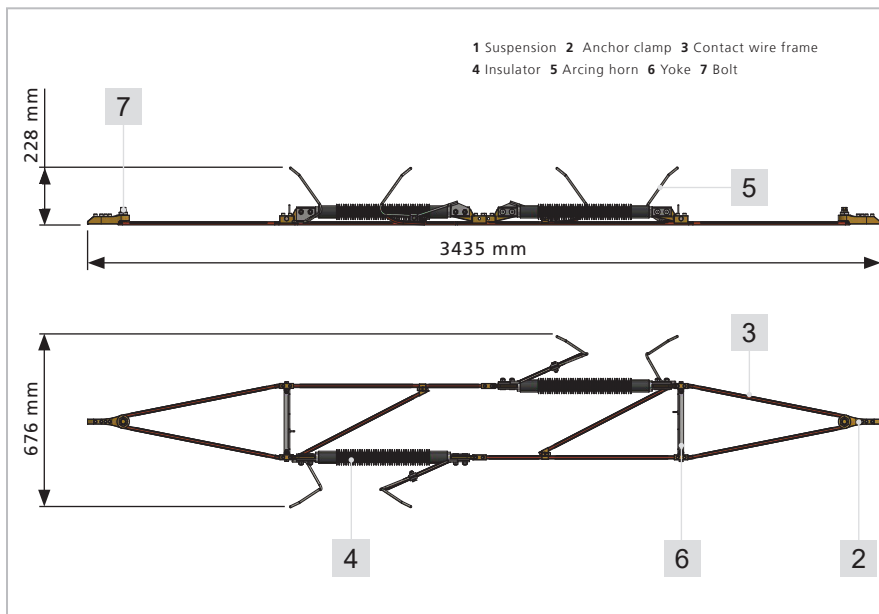
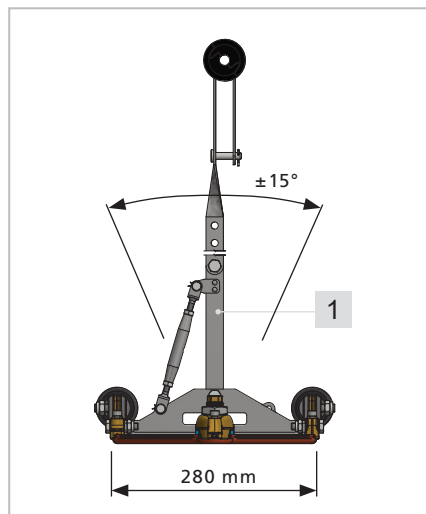
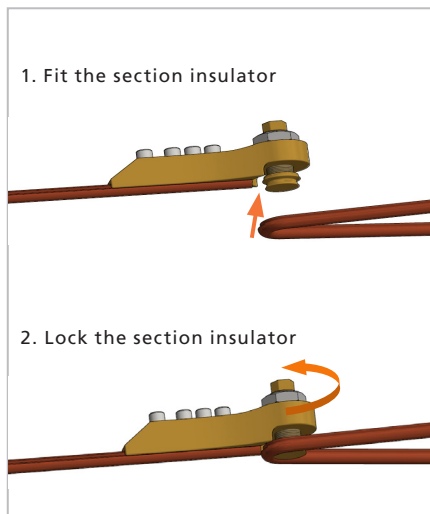

YOUR ADVANTAGES AT A GLANCE

- ✓ -30% Reduction in installation cost
- ✓ At least four times longer service lifetime

- ✓ Application for fixed and auto-tensioned systems
- ✓ Fast changeover thanks to patented anchor clamps
- ✓ Bi-directional use
- ✓ Re-usable anchor clamps
- ✓ Non-traversed insulators
- ✓ Designed for high speeds

SPECIFICATIONS

- ✓ Height: 500–2000 mm
- ✓ Weight: 22 kg
- ✓ Operating voltage: up to 25 kV AC
- ✓ Arc extinguishing capacity: 25 kV / 1500 A / 2 seconds
- ✓ Short-circuit resistance: 40 kA / 100 ms
- ✓ Contact wire cross-section: 100–150 mm²
- ✓ Designed for nominal forces of up to 20 kN
- ✓ Breaking load: Min. 69 kN

TEST AND STANDARDS

- ✓ EN 50119, IEC 60913

PATENT PENDING

- ✓ Patent no. PCT/EP2018/068607

RAILWAY SECTION INSULATOR 15 kV AC

Article no. B1569-01 - Complete with anchor clamps

Article no. B1598-01 - Centre piece with bolt

FAST INSTALLATION ON SITE

In case of a product change, the entire section insulator can be exchanged in next to no time thanks to the patented anchor clamps with their unique installation system.

SIMPLE HEIGHT ADJUSTMENT

The KUSEC 15 kV can be very easily adjusted to the desired height with two perforated suspension plates. The inclination is adjusted with the help of turnbuckles.

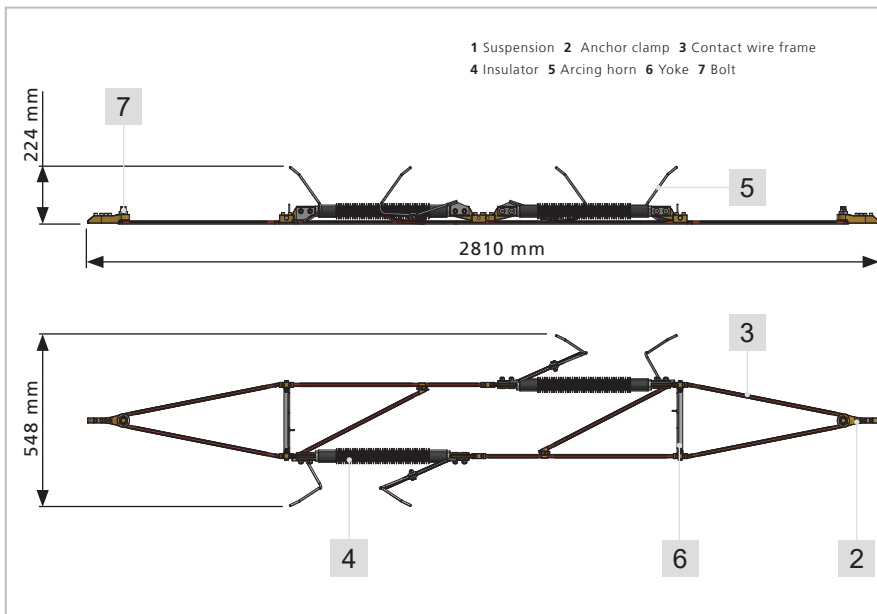
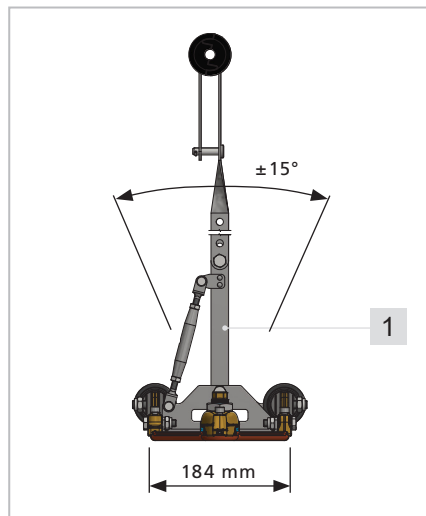
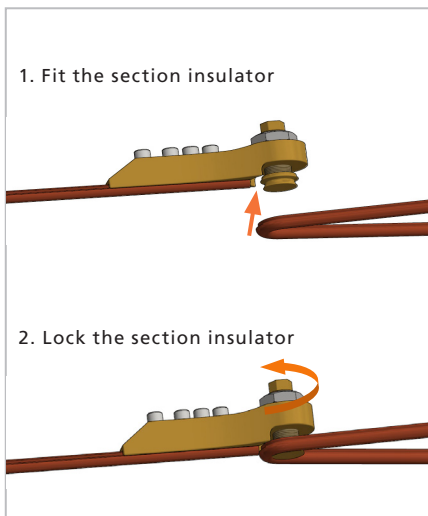

YOUR ADVANTAGES AT A GLANCE

- ✓ -30% Reduction in installation cost
- ✓ At least four times longer service lifetime

- ✓ Application for fixed and auto-tensioned systems
- ✓ Fast changeover thanks to patented anchor clamps
- ✓ Bi-directional use
- ✓ Re-usable anchor clamps
- ✓ Non-traversed insulators
- ✓ Designed for high speeds

SPECIFICATIONS

- ✓ Height: 500–2000 mm
- ✓ Weight: 19 kg
- ✓ Operating voltage: up to 15 kV AC
- ✓ Arc extinguishing capacity: 15 kV / 1500 A / 2 seconds
- ✓ Short-circuit resistance: 40 kA / 100 ms
- ✓ Contact wire cross-section: 100–150 mm²
- ✓ Designed for nominal forces of up to 18 kN
- ✓ Breaking load: Min. 55 kN

TEST AND STANDARDS

- ✓ EN 50119, IEC 60913

PATENT PENDING

- ✓ Patent no. PCT/EP2018/068607

RAILWAY SECTION INSULATOR 3 kV DC

Article no. B1590-01 - Complete with anchor clamps

Article no. B1599-01 - Centre piece with bolt

Suspension: On request

FAST INSTALLATION ON SITE

In case of a product change, the entire section insulator can be exchanged in next to no time thanks to the patented anchor clamps with their unique installation system.

SIMPLE HEIGHT ADJUSTMENT

With the help of hanger wires (1), it is very easy to adapt the KUSEC 3 kV to the on-site conditions, and to install and adjust it.

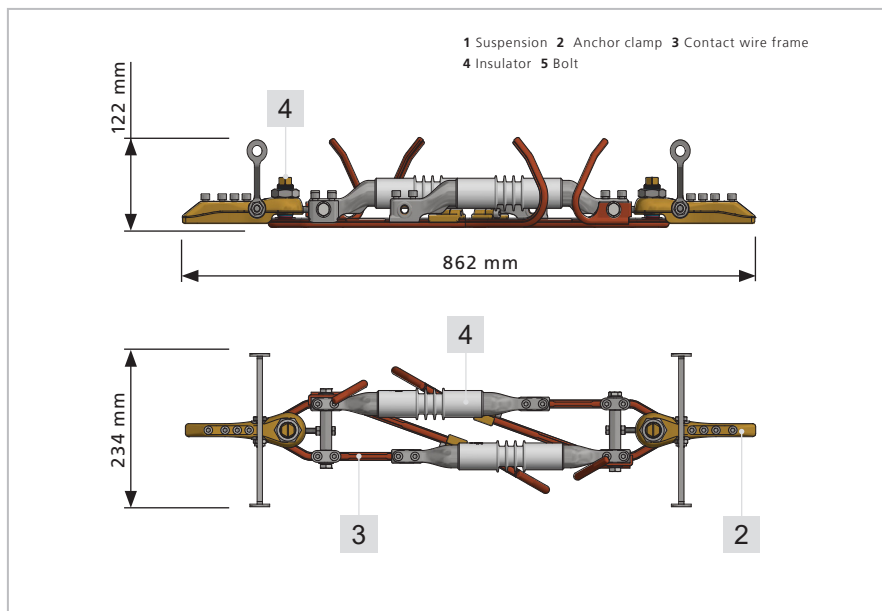
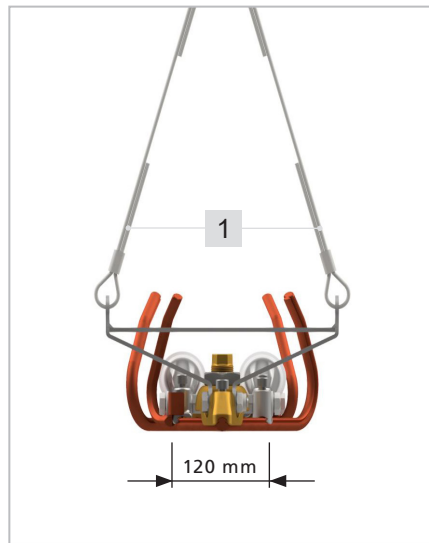
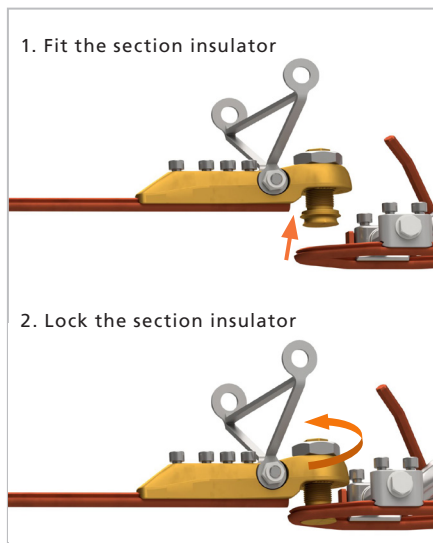

YOUR ADVANTAGES AT A GLANCE

- ✓ -30% Reduction in installation cost
- ✓ Short overall length of 862 mm

- ✓ Application for fixed and auto-tensioned systems
- ✓ Fast changeover thanks to patented anchor clamps
- ✓ Bi-directional use
- ✓ Re-usable anchor clamps
- ✓ Non-traversed insulators

SPECIFICATIONS

- ✓ Weight: 9 kg
- ✓ Operating voltage: up to 3 kV DC
- ✓ Arc extinguishing capacity: 3 kV / 1500 A / 2 seconds
- ✓ Short-circuit resistance: 10 kA / 500 ms
- ✓ Contact wire cross-section: 100–150 mm²
- ✓ Designed for nominal forces of up to 15 kN
- ✓ Breaking load: Min. 49 kN

TEST AND STANDARDS

- ✓ EN 50119, IEC 60913

PATENT PENDING

- ✓ Patent no. PCT/EP2018/068607

Kummler+Matter Ltd
Rietstrasse 14
CH-8108 Dällikon

T +41 44 247 47 47
F +41 44 247 47 77
info.zuerich@kuma.ch

kuma.ch



FOR YOUR OVERHEAD CONTACT LINES